

Pelikan



profim



"The organic shape of the Pelikan is excellent for places requiring longer periods of sitting down: a library, a conference room, a reception room... These armchairs refine the surroundings with a slight touch of natural ease. They satisfy users with their quality and comfort."

Mac Stopa, M. Ballendat
Product Designers



reddot design award
winner 2015

Joy found in breaking conventions.

The design of Pelikan collection refers to the harmony of nature – it makes you think of organic lines and structures. The natural shape of the armchair, as well as the surprising concept of using the additional space – these are distinctive features of Pelikan.











Eye-catching and practical

Pelikan's originality was awarded the most prestigious title in the design world, Red Dot Award 2015. No wonder, this solution is an innovative idea for combining a seat with a shelf. The pocket provides place for documents, a laptop or a bag.



reddot design award
winner 2015



Designed for creative minds

This collection is for those who like bold space arrangements and unique furniture with a character. Pelikan helps to build environment that fosters both: creative work and effective relaxation.



The special version of Pelikan in „Waves of Creativity“ upholstery, presented as part of „Energy for Creativity“ installation at Salone del Mobile 2015. Available early 2016.





ACCESSORIES



HERRING-
BONE

ZIG
ZAG

HOUNDS-
TOOTH

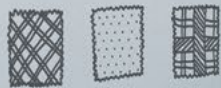

STRIPS

DOTTED

PANED



WOOD

METAL

FABRICS

CHECKLIST

- CHAIR MODELS ✓
- COLOURS/FABRICS ✓
- PATTERNS ✓
- TEXTURES
- ACCESSORIES ?



ERNS
ICS



Configure your product

When ordering, please use code symbols.

Pelikan



Shell

Frame / Base



Upholstered, with felt shelf¹

10



4-legged

Available early 2016.

H



4-legged with castors

Available early 2016.

HC



Cantilever

Available early 2016.

V



Swivel, round base

R



Swivel, 4-star base

F

¹ felt always in graphite grey.

² items in black upholstery: threads always white; items in other colours of upholstery: threads always black.

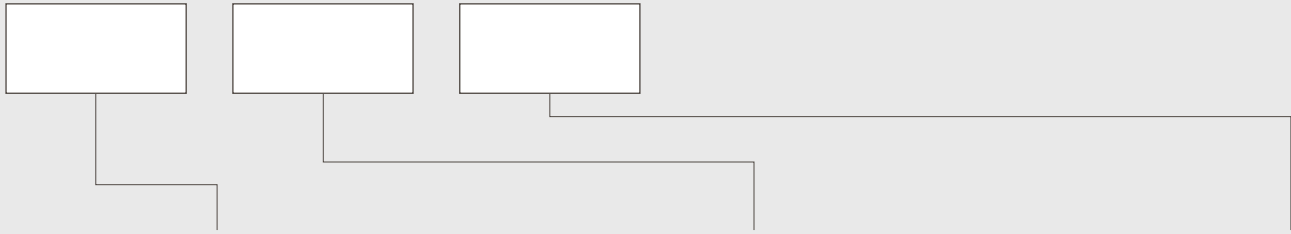

Frame / base colour



BLACK

Applicable for H, HC, V versions.



METALLIC

Applicable for H, HC, V, R versions.



CHROME



SATINE

Applicable for H, HC, V versions.

Armrests



Polyurethane (PU)
Applicable for R, F versions.

2P

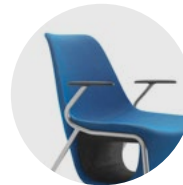

Metal, intergrated with the frame, with polyurethane pad (PU)
Applicable for H, HC, V versions.

2P

Colour of armrests
Applicable for R, F versions.



RAL 9005

Black



RAL 7043

Grey



RAL 3031

Red



RAL 5024

Blue



RAL 6018

Green

Upholstery

Type & colour

SYMBOL

Additional

Threads



Threads in the same colour as upholstery.

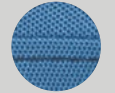

Contrast threads.²

Castors



HARD

For soft floors.



SOFT

For hard floors.

Castors are equipped with a brake that prevents the chair from „moving away“ without a load.

Gaslift with memory
Applicable for R version.



Measurements

The measurements are approximate and can differ depending on the product configuration.
 Measuring methodology is available at this link: www.profim.eu/Measuring_methodology.pdf

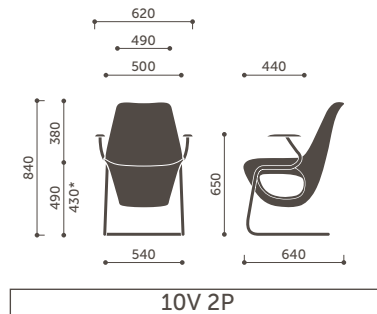
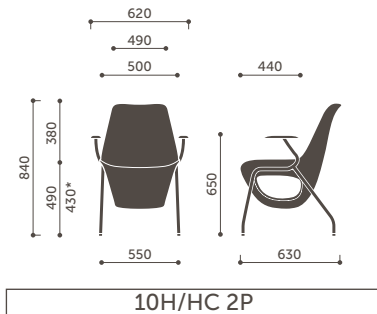
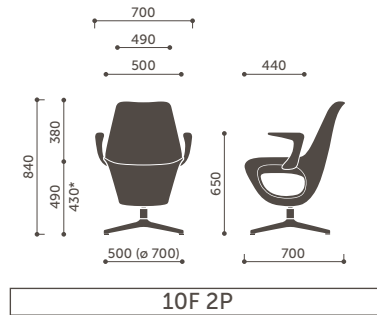
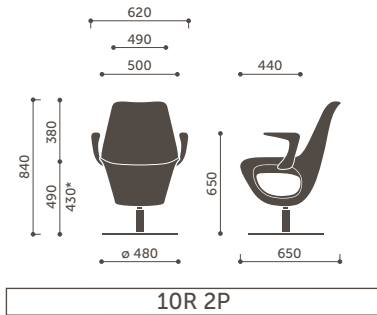

* Seat height is measured according to PN EN 16139 norm (with seat burden).



Profim and the Environment

In our operation we follow the sustainability principle. We operate in a responsible manner for the benefit of our customers, employees, suppliers, and the local community, but we always respect the environment.

In order to achieve our goals, we have implemented Environmental Management System based on the ISO 14001 standard, which allows for a comprehensive approach to ecology. We take into consideration and evaluate the way Pelikan products affect the environment during their entire life cycle.

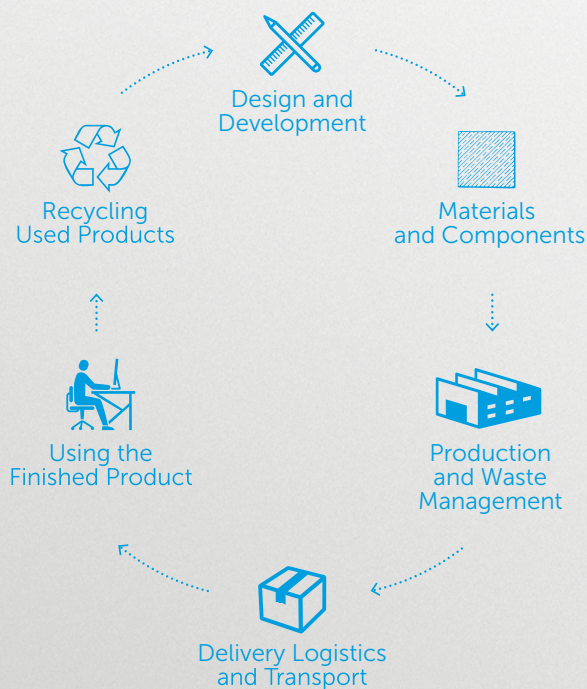

For more information about the product please scan the QR code.



Pelikan

Product Environmental Information

(for Pelikan 10R 2P)

Materials used:

Metals	kg	%
Steel	21,70	85,0
Plastics	kg	%
Polyurethane (PUR)	3,05	11,9
Polypropylene (PP)	0,33	1,3
Others	kg	%
Upholstery	0,47	1,8
Weight	25,54	100

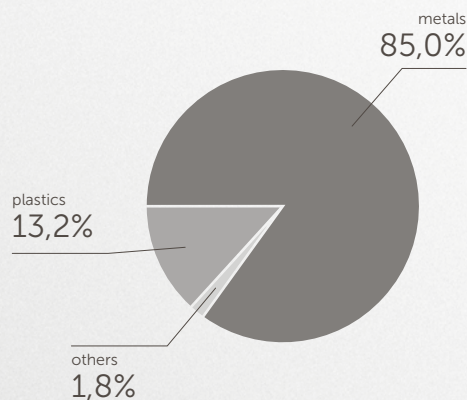

This product contains no chemical compounds harmful to human health or the environment (including PVC, chromium (VI), mercury or lead).

www.profim.eu

The producer reserves the right to conduct construction changes and improvements of the products.
Colours presented in the catalogue may vary from the original colours of furniture.



CHROMIUM (III)
Eco-Friendly Technology

CHROM (III)
Umweltfreundliche
Technologie

